

Variable Frequency Drive by Using ARM Controller

Nilesh kumbhar¹, Rohit Chinchkar², Gaurav Dhane³, Aruna Jadhav⁴

Asst. Professor, Dept. of Electrical Engg, AMGOI, Vathar Tarf Vadgaon, India¹

Student, Dept. of Electrical Engg, AMGOI, Vathar Tarf Vadgaon, India^{2,3,4}

Abstract: Now day’s induction motors are broadly used for variable load application, because load on induction motor is not unceasing for each time and it’s varying as per load requirement. So it’s necessary to change the speed of induction motor as per load variation. Motor speed is directly proportional to the supply voltage and inversely proportional to the supply frequency. The ratio of voltage and frequency must be kept constant during speed control. For maintaining v/f ratio VFD method is used. In VFD pulse width modulation technology are used to control the speed motor. This aim is achieved by using ARM controller. By comparing another speed control methods, VFD method is predominant.

Keywords: unceasing, variable frequency drive, H bridge inverter, ARM controller, Keil, protieus

I. INTRODUCTION

Induction motors have many advantages compared to DC motors and synchronous motors in many aspects, such as size, efficiency, cost, life span and maintainability. Also the Induction motors are widely used in many residential, industrial, commercial, and utility applications. Single-phase induction motors are widely used in home appliances and industrial control. Variable frequency drive (VFD) is a system for controlling the speed of electric motor by changing the supply frequency and supply voltage. Variable frequency drive is also called as variable speed drive (VSD) or adjustable frequency drive (AFD)

This device uses power electronics component to vary the frequency of input power to the motor, thereby controlling motor speed. Single phase induction motor is controlled by ARM controller through inverter circuit. The speed of AC motor can be control by changing the duty cycle (PWM).As per requirement we need to control the speed of single phase induction motor and this can be achieved by using ARM-7 (LPC-2148).

It has inbuilt feature of PWM technique. This feature is used to produces pulses of varying width which are combined to build the required waveform. This signal is processed and given to the motor to control the speed. Synchronous speed is denoted by N_s . Synchronous speed of induction motor is depends on supply frequency and Number of poles. So, motor speed can be change by changing the supply frequency. But changing only frequency has limitations. If only frequency reduces then there is possibility of core saturation. Also constant torque capabilities of motor decreases, so voltage-frequency ratio is kept constant.

II. V/F CONTROL

The understanding of three basic section of VFD the Rectifier unit, processing unit and the Inverter unit requires for understanding basic principles of VFD operation.

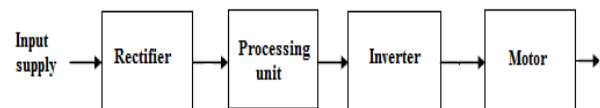

Fig 2.1 Block Diagram of VFD

1. Rectifier:

The supply voltage is firstly passing through a rectifier unit which convert it into AC to DC supply. The single phase supply is fed with single phase full wave diode where it get converted into DC supply

2. Processing Unit:

In this unit ARM 7 is used to produces pulses of varying widths (PWM) on the basis of written program.

3. Inverter:-

Inverter is a converting device which converts DC voltage into AC voltage. PWM signals combined to build the required waveform. This signal is processed and given to the motor to control the speed.

As we know that the synchronous speed of motor (rpm) is dependent upon frequency. The synchronous motor speed can be controlled b varying the supply frequency through VFD.

Synchronous speed is given by,

$$\text{Speed (rpm)} = 120F/P$$

Where,

F= supply frequency in Hz

P= Number of poles

The frequency of motor is changed to adjust the speed of motor and also change speed can be done by changing no. of poles of motor, but this change would be a physical change of the motor. As the frequency can easily variable as compared with the poles of the motor therefore speed control drive is termed as Variable Frequency Drive (VFD).

The torque developed by the induction motor is directly proportional to the ratio of the applied voltage and the

supply frequency. The torque developed can be kept constant by changing the voltage and frequency but keeping their ratio constant.

III. GENERATION OF PULSE WIDTH MODULATION

PWM or pulse width modulation is a simplest method of control the power to load without dissipates in load. When the signal is high, represent 'ON' interval. The amount of ON time we use the concept of duty cycle. Normally Duty cycle represent is in form of percentage. The percentage duty cycle specifically describe the percentage of time a digital signal is over an interval or period of time. This period is the inverse of the frequency of the waveform.

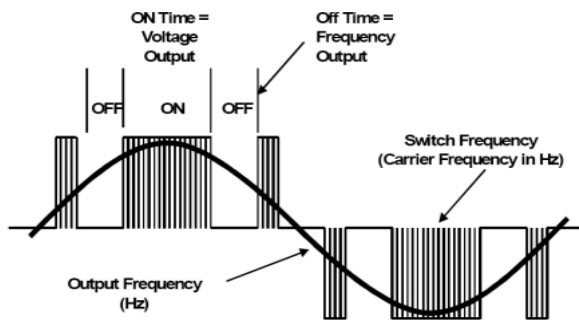

Fig. 3.1 Drive output waveform

If digital signals spend half of the time on the other half off, we should say the digital signal as a duty cycle of 50% and resemble an ideal square wave. If the digital signal spends more time in the high state than the low state, indicate that percentage is higher than 50% and vice versa if the duty cycle is less than 50%

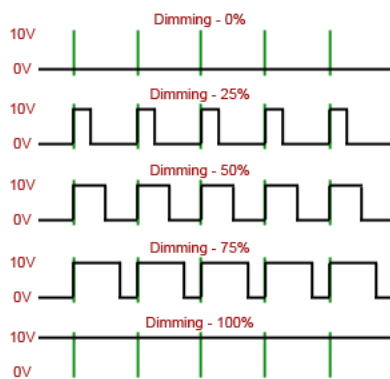

Fig. 3.2 Duty cycle

IV. GENERATION OF PULSE WIDTH MODULATION

The simulation for generation of PWM is done by using proteus software. Here need to generate a PWM in LPC2148 ARM Controller at particular frequency. Pulse width modulation is a technique for getting results with digital means. Digital control is used to create a square wave, ON and OFF time of signal can be adjust V/F in between full on and off by changing the duty cycle. The duration of on and off is called pulse width.

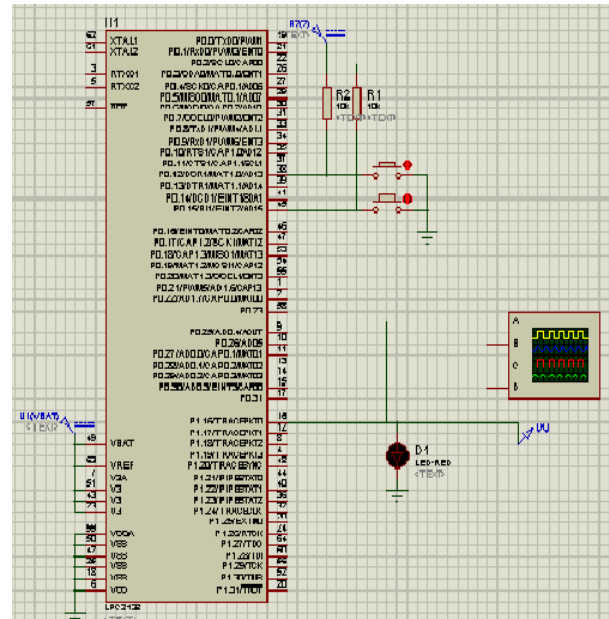

Fig. 4.1 Simulation of VFD

1. Simulation output

Following fig. shows that the various duty cycle in persentage on proteus software.

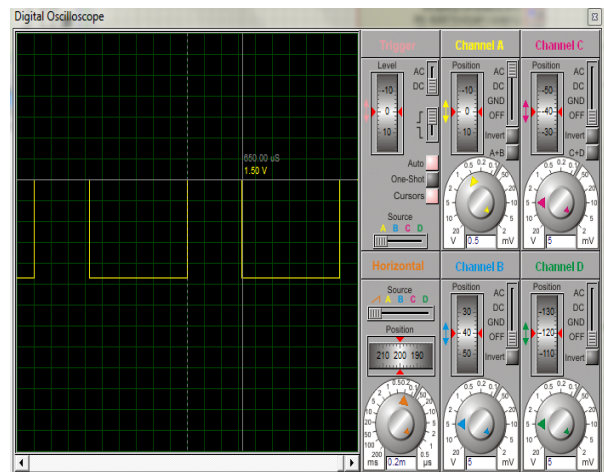

Fig. (a) 30% Duty cycle

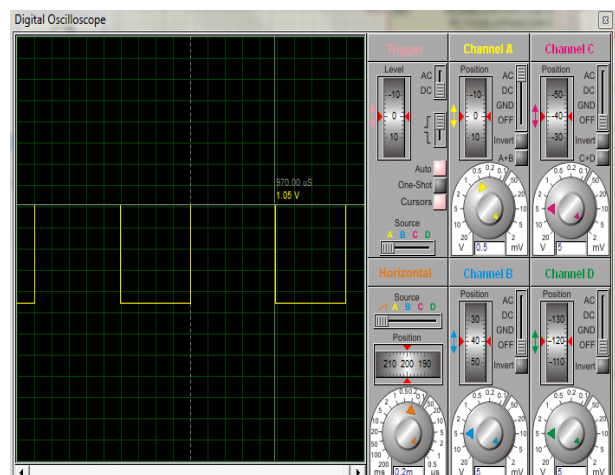

Fig. (b) 60 % Duty cycle

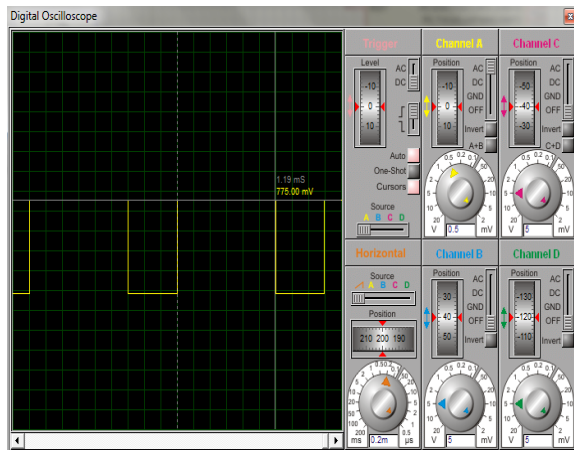

Fig. (c) 70% Duty cycle



Mr. Gaurav Dhane working as a student in the Department of Electrical Engineering of Ashokrao Mane Group of Institution, Vathar tarf Vadgaon, Kolhapur, Maharashtra.



Mr. Rohit Chinchkar working as a student in the Department of Electrical Engineering of Ashokrao Mane Group of Institution, Vathar tarf Vadgaon, Kolhapur, Maharashtra.

ADVANTAGES:

1. Low starting current of motor.
2. Reduction of mechanical stresses and thermal on motor and belt during start.
3. Simple installation
4. Speed can be easily control.

APPLICATION:

1. Domestic and industrial application
2. Centrifugal pumps.
3. Fan and blowers

V. CONCLUSION

Hence we conclude that adding a variable frequency drive to a motor driver system can offer potential energy saving in a system in which the load varies with time. Operating speed of motor is varied by changing the frequency of the motor supply voltage.

VFD can be used for induction motor and speed can get control as per load requirement so energy consumption gets reduced.

REFERENCES

1. Pooja Shinde¹, Rupali Burungale², Pooja Kale³, Purvee Jain⁴ “Speed Control of Induction Motor by Using Variable Frequency Drive” ISSN : 2248-9622, Vol. 4, Issue 4(Version 8), April 2014, pp.35-37
2. Chaitanya N.Jibhakate, Asstt.Prof.(Mrs.)Vijaya Huchche “Speed Control of Single Phase Induction Motor Using Micro-Controller” International Journal of Engineering Research and Applications (IJERA) ISSN: 2248-9622 International Conference on Industrial Automation and Computing (ICIAC-12-13th April 2014)
3. Tamal Aditya “Research to study Variable Frequency Drive and its Energy Savings” International Journal of Science and Research (IJSR), India Online ISSN: 2319-7064
4. B. L. Theraja. A. K. Theraja A text book of electrical technology.

BIOGRAPHIES



Prof. N. J. Kumbhar working as a assistant professor in the Department of Electrical Engineering of Ashokrao Mane Group of Institution, Vathar tarf Vadgaon, Kolhapur, Maharashtra.